

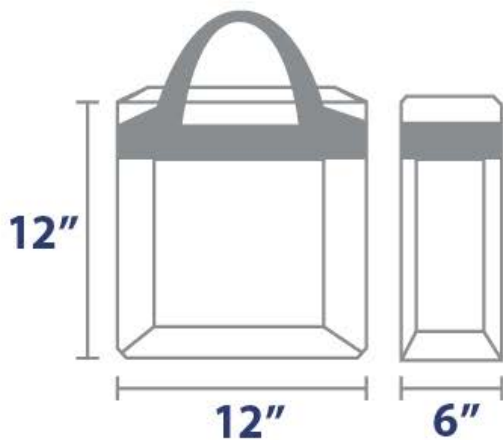

DOBSON HIGH SCHOOL BAG PROTOCOL

APPROVED BAGS

CLEAR PLASTIC, VINYL, OR PVC BAG



No larger than
12" x 6" x 12"

SMALL CLUTCH BAG

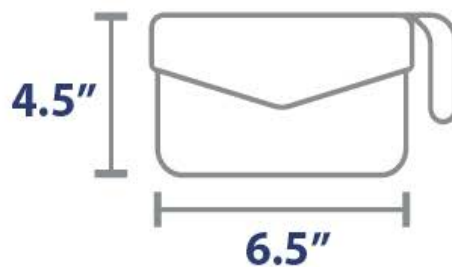

No larger than
(4.5" x 6.5") with or
without a handle
or strap

ONE-GALLON CLEAR PLASTIC FREEZER BAG

(Ziploc bag or similar)

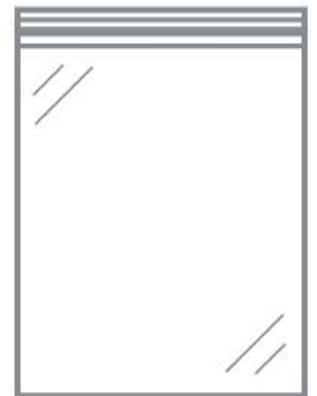

Medical bags are permitted but subject to an inspection

NON-APPROVED BAGS

- Backpacks
- Large Purse
- Fanny Pack
- Camera Bag
- Oversized Tote Bag
- Diaper Bag
- Binoculars Case
- Mesh Bag
- Tinted Colored or Pattern Plastic Bag
- Drawstring Bag



DOBSON HIGH SCHOOL PROTOCOLO DE BOLSA

BOLSAS APROBADAS

BOLSA DE PLÁSTICO TRANSPARENTE, VINILO O PVC

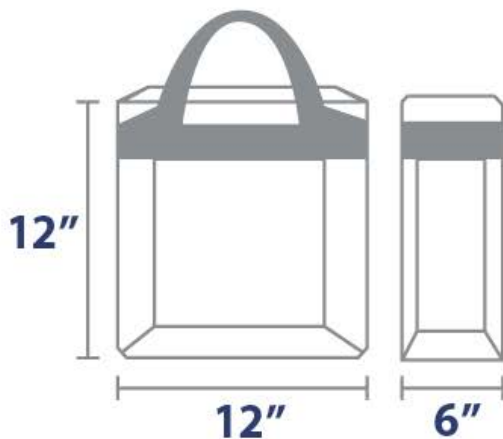

No más grande que
12" x 6" x 12"

BOLSO DE EMBRAGUE PEQUEÑO

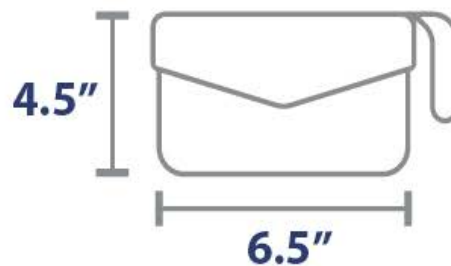

No más grande que
(4.5" x 6.5") con o sin
mango o correa

BOLSA DE PLÁSTICO TRANSPARENTE PARA CONGELADOR DE UN GALÓN

(Bolsa Ziploc o similar)

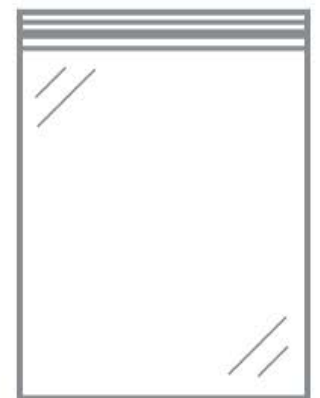

Las bolsas médicas están permitidas pero sujetas a una inspección

BOLSAS NO APROBADAS

- Mochilas
- Bolso grande
- Riñonera
- Estuche para la cámara
- Bolsón extra grande
- Bolsa de pañales
- Estuche de binoculares
- Bolsa de malla
- Bolsa de plástico teñida de color o patrón
- Mochila con cordón de ajuste